

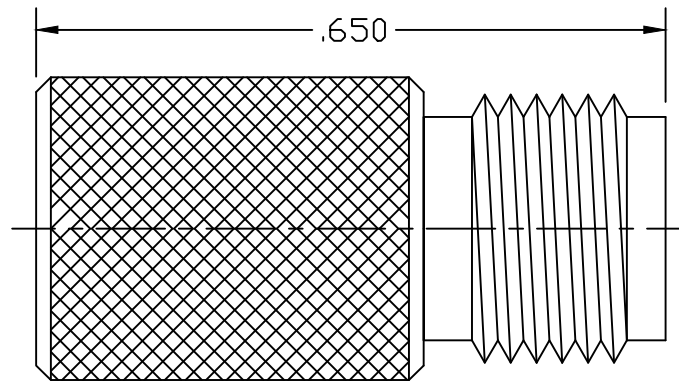

NOTES:

010-99-043



LTR	DESCRIPTION	DATE	APPR.	DRAWN <i>LMW</i>	CHECKED	USED ON	 SRI CONNECTOR GAGE CO. 751 NORTH DRIVE MELBOURNE FL. 32934		
-	REL	09/03		APPR.	SCALE	2.9mm TO .085 S/R			
				UNLESS OTHERWISE SPECIFIED: 1. REMOVE ALL BURRS 2. BREAK ALL CORNERS & EDGES .005 R. MAX 3. CHAMFER 1st & LAST THREADS 45° 4. SURFACE FINISHED 32/ UNLESS OTHERWISE SPECIFIED. 5. DIAMETERS ON COMMON CENTERS TO BE CONCENTRIC WITHIN .002 T.I.R. 6. ALL DIMENSIONS ARE AFTER PLATING.			MATERIAL	TITLE	
				DIMENSIONS ARE IN INCHES TOLERANCES			FINISH	ASSEMBLY TOOL 2.9mm TO .085 S/R	
				DECIMALS      FRACTIONAL      ANGULAR .X            ±.030 .XX          ±.010            ± 1/64      .X°    ±1°0' .XXX        +.005            .X°X'   ±15'	SIZE	FSCM NO.	SHEET		DWG. NO.
						A	OHMO1	1	010-99-043