

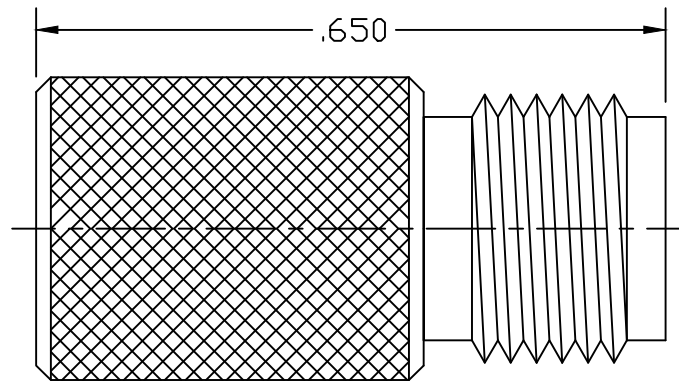

NOTES:

010-27-016



LTR	DESCRIPTION	DATE	APPR.	DRAWN <i>LMW</i>	CHECKED	USED ON	 SRI CONNECTOR GAGE CO. 751 NORTH DRIVE MELBOURNE FL. 32934		
-	REL	09/03		APPR.	SCALE	2.4mm TO .085 S/R			
				UNLESS OTHERWISE SPECIFIED: 1. REMOVE ALL BURRS 2. BREAK ALL CORNERS & EDGES .005 R. MAX 3. CHAMFER 1st & LAST THREADS 45° 4. SURFACE FINISHED 32/ UNLESS OTHERWISE SPECIFIED. 5. DIAMETERS ON COMMON CENTERS TO BE CONCENTRIC WITHIN .002 T.I.R. 6. ALL DIMENSIONS ARE AFTER PLATING.		MATERIAL	TITLE		
				DIMENSIONS ARE IN INCHES TOLERANCES		FINISH	ASSEMBLY TOOL 2.4mm TO .085 S/R		
				DECIMALS FRACTIONAL ANGULAR .X ±.030 .XX ±.010 ± 1/64 .X° ±1°0' .XXX +.005 .X°X' ±15'	SIZE	FSCM NO.		SHEET	DWG. NO.
					A	OHMO1		1	010-27-016